

ROTARY

STORAGE SYSTEMS



MAXIMUM SPACE EFFICIENCY

Maximizing office floor space is essential, given today's high facilities costs. Spacesaver Rotary Storage Systems are the space-efficient and cost-effective alternative to lateral and vertical files. Rotary Storage offers the same or greater capacity as conventional file cabinets in a fraction of the floor space. And Spacesaver meets virtually every height requirement in the industry. Spacesaver Rotary Storage allows you to do more with less – less space, less time and less labor.



Rotating Back-To-Back Storage Components Spacesaver Rotary Storage units rotate to provide easy access to back-to-back storage compartments. When not in use, files can be locked in the closed position, presenting a clean, uncluttered appearance.



Roll-Out Reference Shelves Optional roll-out reference shelves serve as handy work surfaces, making storage and retrieval more efficient, while providing a convenient way to review materials on the spot.



Sturdy Drawer Guides Drawers roll out on sturdy ball-bearing guides, providing years of smooth, trouble-free operation.



Simple Operation To rotate, simply depress the foot pedal and gently push. Spacesaver Rotary Storage automatically stops in the next position – either fully-opened or fully-closed. To address ADA issues, just lock the foot pedal in the “freespin” position. The optional Rotary Storage TouchPad Release, a waist-high, electronic keypad control, provides an extra measure of security, while offering an ADA-friendly alternative to the mechanical foot pedal and key lock.







MAXIMUM FLEXIBILITY

The greater capacity of Spacesaver Rotary Storage over traditional lateral and vertical files, is the result of innovative back-to-back revolving storage compartments. Our Rotary Storage units rotate to give access to two banks of stored materials, increasing flexibility in office design. Choose single-sided access when using them in alcoves or against walls and panels. Choose double-sided access when using them as room dividers. Either approach is effective when you want a space-saving way to share storage between workstations.

Security Drawers For restricted access to confidential information or maintaining privacy for multiple users, Security Drawers are the answer. Simply issue keys to authorized personnel.



Key Lock Options You decide whether one key unlocks multiple units or just one. The Rotary Storage key can be coordinated with Spacesaver modular door and drawer products – another Spacesaver innovation.



Touchpad Keyless entry means no more keys to track or lose.



Secure Drawer Latches Drawer latches, complete with torsion springs, keep drawers securely closed when not in use – another exclusive Spacesaver design feature.



Adjustable Drawers and Shelving Drawers and shelves can be adjusted vertically in increments of 1-3/4" (44 mm), permitting a wide variety of custom configurations. Fixed shelves snap into place without the use of hardware. Drawers and Roll-Out Shelves attach easily in seconds with our matching set screw design. It's just one reason our drawer options are the most versatile in the industry.



TYPE OF STORAGE

WHAT CAN BE STORED IN A SPACESAVER ROTARY STORAGE SYSTEM?

Virtually any type of material, including binders, CD's, videos, supplies and, of course, hanging files. Our rotary units function as efficient multi-media storage systems. A wide variety of items can be stored in the same cabinet. As your needs change, interior drawers and shelving can easily be reconfigured. When more capacity is needed, additional units can also be added.

Spacesaver Rotary Storage is available in a variety of colors to complement any office interior decor. To ensure lasting good looks, the durable powder-coated finish is textured to conceal fingerprints and smudges. But the real beauty is in its functionality. Spacesaver's high-capacity Rotary Storage Systems are an innovative way to conserve floor space and lower storage costs.

GREATER STORAGE CAPACITY/LOWER COSTS

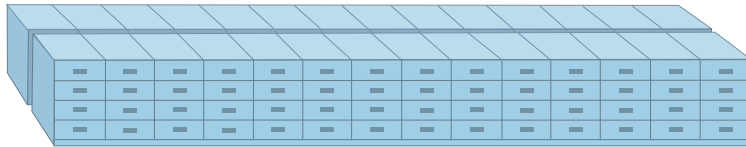

4-DRAWER LATERAL FILES

10.6 Linear File Inches/Sq. Foot
2.9 Linear File Meters/Sq. Meter

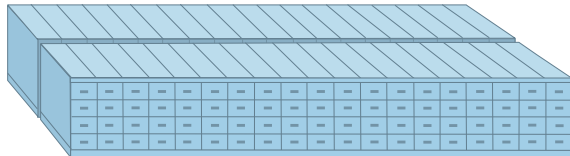

4-DRAWER VERTICAL FILES

14.5 Linear File Inches/Sq. Foot
4.0 Linear File Meters/Sq. Meter

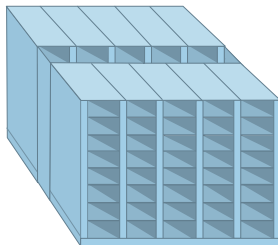

SPACESAVER 8-TIER ROTARY STORAGE

27.4 Linear File Inches/Sq. Foot
7.5 Linear File Meters/Sq. Meter

These 10 Rotary Storage units hold the same amount of materials as 28 4-drawer lateral or 38 4-drawer vertical files.

Each of the systems shown above provide the same storage capacity, but Spacesaver Rotary Storage units consume less than half the floor space. The net result – Spacesaver Rotary Storage Systems are a better, more space-efficient way to lower your storage costs.



MIX & MATCH

MIX AND MATCH ROTARY UNITS TO MEET YOUR INDIVIDUAL REQUIREMENTS

Shown below are five Spacesaver 7-tier Rotary Storage units, configured as one Starter Unit with four Adder Units.

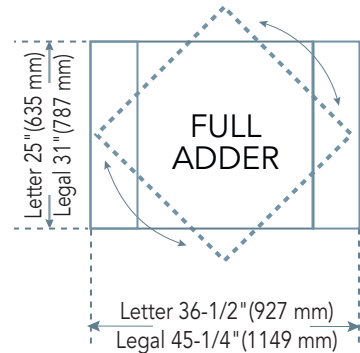
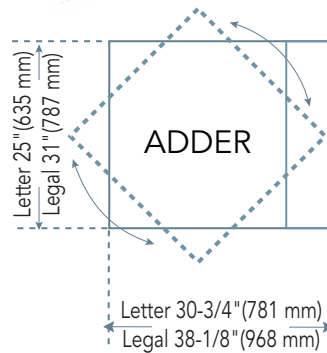
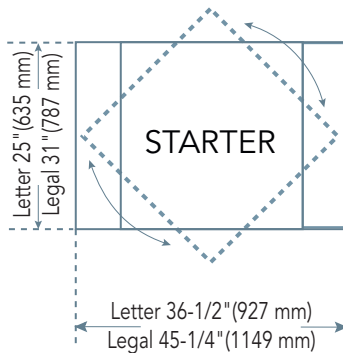
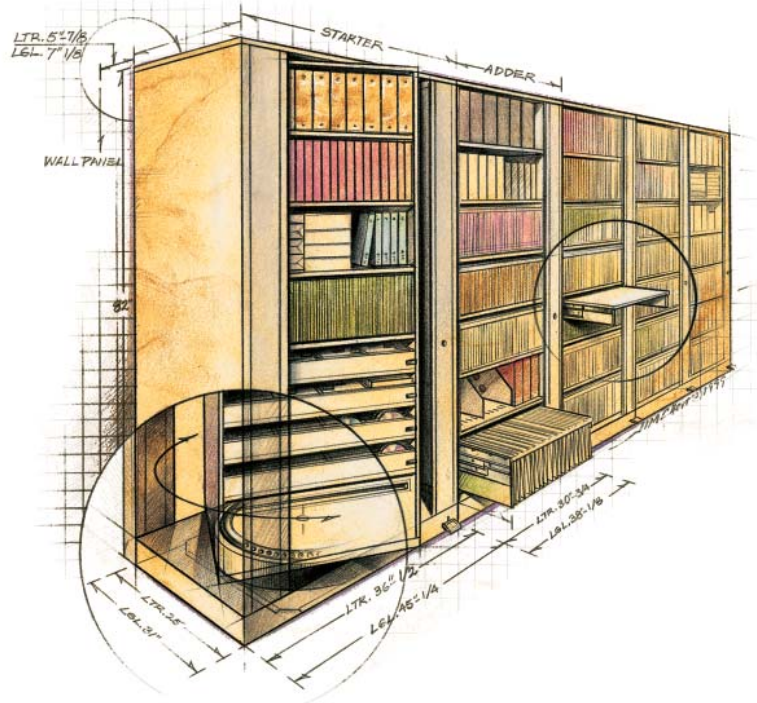

STARTER

The first cabinet in any row of Spacesaver Rotary Storage units is always a Starter. This unit can stand alone, or Adder units can be connected to either side.

ADDER

Sharing rotation space with their neighbors, Adder units reduce the necessary floor space of a Starter by 6 inches in width. The number of Rotary Storage units that can be connected together is limited only by the physical constraints of your space plan.

FULL ADDER

Where active files demand increased accessibility, a Full Adder allows the freedom of simultaneous access to adjoining units. Connected to a Starter, the Full Adder does not share rotation space with its neighbor.

SPECIFICATIONS

DIMENSIONAL SPECIFICATIONS

The heights, widths, depths and capacities of Spacesaver Rotary Storage units are shown below. Consult your local Area Contractor for recommended configurations.

STARTERS AND ADDERS

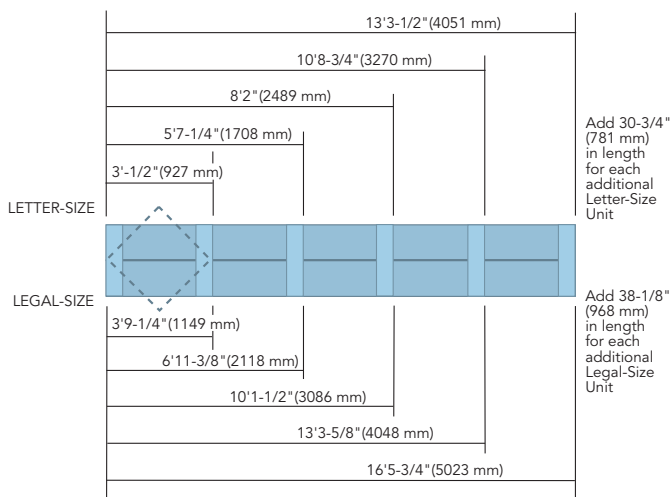

STARTERS AND FULL ADDERS

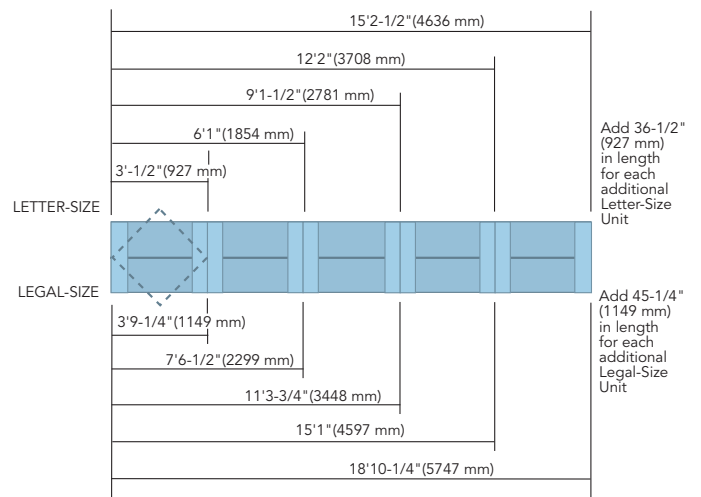

UNIT HEIGHTS

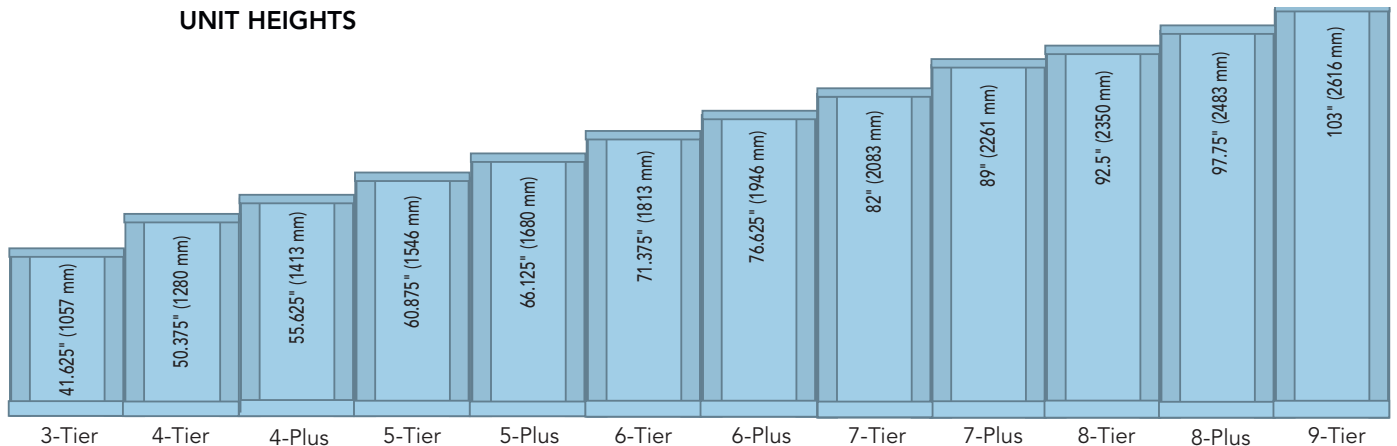

Configuration	Capacity (Letter)	Capacity (Legal)
3-Tier	144 linear file inches (3658 mm)	180 linear file inches (4572 mm)
4-Tier	192 linear file inches (4877 mm)	240 linear file inches (6096 mm)
4-Plus	192 linear file inches (4877 mm)	240 linear file inches (6096 mm)
5-Tier	240 linear file inches (6096 mm)	300 linear file inches (7620 mm)
5-Plus	240 linear file inches (6096 mm)	300 linear file inches (7620 mm)
6-Tier	288 linear file inches (7315 mm)	360 linear file inches (9144 mm)
6-Plus	288 linear file inches (7315 mm)	360 linear file inches (9144 mm)
7-Tier	336 linear file inches (8534 mm)	420 linear file inches (10668 mm)
7-Plus	336 linear file inches (8534 mm)	420 linear file inches (10668 mm)
8-Tier	384 linear file inches (9754 mm)	480 linear file inches (12192 mm)
8-Plus	384 linear file inches (9754 mm)	480 linear file inches (12192 mm)
9-Tier	432 linear file inches (10973 mm)	540 linear file inches (13716 mm)



Spacesaver Corporation
1450 Janesville Avenue
Fort Atkinson, WI 53538-2798
1-800-492-3434
www.spacesaver.com



KI
1330 Bellevue Street
P.O. Box 8100
Green Bay, WI 54302-8100
1-800-424-2432
www.ki.com

Spacesaver Corporation is a division of KI.
KI is a registered trademark of Krueger International, Inc.
Spacesaver is a registered trademark of Spacesaver Corporation.
© 2009 KI and Spacesaver Corporation. All Rights Reserved. Litho in USA. SC-0130 SSC/MRK 12/09